



## Shiftable Unicycle Hub, Type KH

## Warranty

**schlumpf innovations gmbh** grants a warranty of 5 years following the purchase date for hub material and workmanship including all internal components such as gears, axle, shifting shaft, clutch, internal bearings.

The warranty is **not** granted for the following damages:

- Corrosion caused by improper cleaning (no high pressure water)
- Damages caused by lack of lubrication (please remember, that the hub has to be lubricated once or twice a year with some bicycle oil or our special grease)
- Material defects caused by excessive load (e.g. high drops / limit is 1.5m)
- Damage due to impact by hard objects (e.g. gear shift buttons hitting rock)
- Damages caused by improper installation of crankarms
- Damages of the axle bearings caused by excessive tightening (always use torque wrench!)
- Damages caused by wrong adjustment of gear shift buttons
- Damages caused by general wear and tear, such as bearings wearing out
- Damage to any components other than the hub, that may be covered by other warranties (e.g. crank arms)

**Please notice: warranty expires if housing is opened!**

## Tools included in shipment

- Allen wrench 2.0mm
- Allen bit 6mm for 3/8" wrench or torque wrench
- Wrench for holding gear shift button



## News 2011 at a glance



Outer protection rings with a labyrinth gap of 0.1mm guard against entry of dust or spray water.

Inner protection rings with a labyrinth gap of 0.1mm guard against entry of dust or spray water.

Reinforced rim for even higher resistance against broken spoke holes



Countersunk parts on both sides of spoke holes: spokes can be fitted from both sides. No danger of wrong installation.



## Installation

### 1. Which frames fit the Kris Holm Schlumpf hub?

Please check first, if the frame size and shape allows to fit the hub:

- Frames with 42mm bearing housings, where the lip on the inside edge of the bearing housing is less than 2mm high. All Kris Holm frames manufactured after September 2006 fit this hub. KH frames made in 2005 and early 2006 contain a 4mm high bearing housing lip and require modification to fit the hub.

- Bearing housings must be of the type that securely clamp on both sides with bolts. Pressed-in bearing housings (e.g. picture 3) are not compatible because they will slip under load in high gear mode.

### 2. Spokes

The hub has 36 spokes holes, designed for 2mm spokes.

**Hubs from serie 2011 come with countersunk holes on both sides -> spokes can't be mounted the wrong way.**

The correct lengths vary according to the rim type. Please use our spokes calculator on our website to find out the spoke length.

Some approximate lengths (for triple crossing):

- 20"-rim: spokes length about 165mm
- 24"-rim: spokes length about 230mm
- 26"-rim: spokes length about 242mm
- 28"-rim: spokes length about 280mm

More infos on [www.krisholm.com](http://www.krisholm.com)

### 3. Fitting the hub

Look at the bearings on each side of the hub. You will see that one has a smooth surface, and the other has a knurled (rough) surface.

Put the hub on the frame. Check that the inside lip of the bearing housing does not interfere with the corresponding parts of the hub (see picture 1).

Tighten the Allen screws on the side with the knurled bearing surface to moderate hand pressure (5-6 Nm). The knurled bearing surface will act as a brace against the tightened bearing housing when you are in high gear mode. Tighten the smooth bearing housing on the other side to slight hand pressure (5 Nm).

**Important: Do not over-tighten the bearing housings (either side). Excessive tightening is not required to hold the knurled bearing in place and will cause bearing damage that is not covered by warranty.**

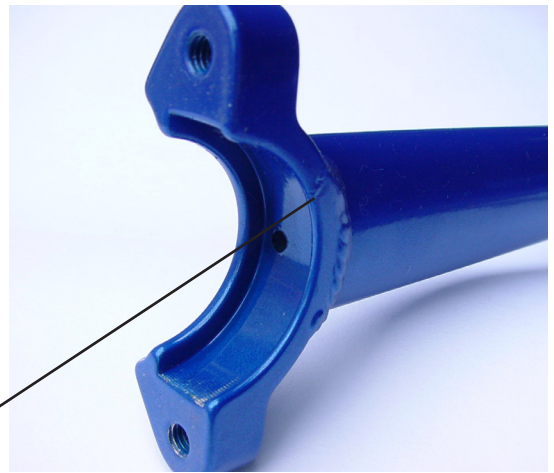

Picture 1: Check dimensions of the inner shoulder

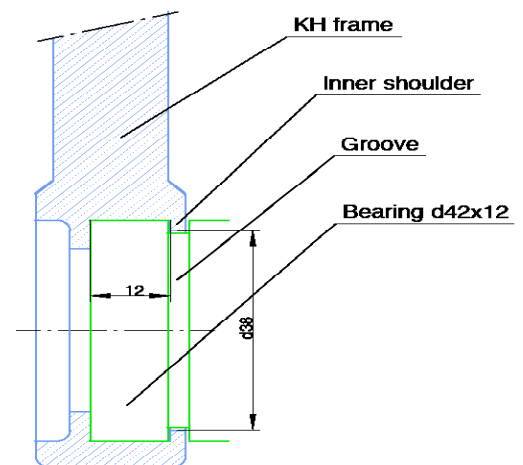

Picture 2: Bearing holder situation

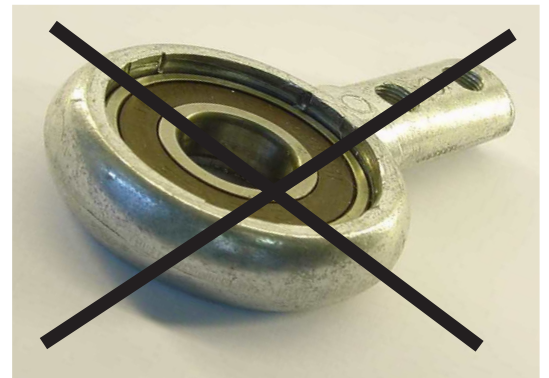

Picture 3: Do not use pressed in bearing holders. The geared hub would slip under load in high gear mode!



Picture 4: Tighten the screws evenly with 5-6 Nm!

#### **4. Which crank arms fit the KH hub?**

The KH-Schlumpf hub is designed for Kris Holm Moment cranks and other cranks that fit both an ISIS spline pattern and the shifter mechanisms. If using crank arms other than KH Moment cranks, check for compatibility **prior** to installation. Put an axle bolt and gear shift button into the hole of the (uninstalled) crank and check that there is enough space. After mounting and tightening, please always check, if the shifting mechanism jumps from one position into the other without any friction!!

#### **5. Fitting the crankarm**

Put the crankarms on the axle and give some moderate hits with a plastic hammer to get them a proper seat. Use some thread compound (Loctite, medium strength) for the axle bolt. Please use a torque wrench and tighten to 40 - 50 Nm (35 lbft).

If the shifting shaft protrudes, push it inwards using the Allen wrench to make sure, that the wrench engages properly. Re-tighten the axle bolt after the first few kilometers.

#### **6. Mounting and tightening gear shift buttons**

Screw in the gearshift button about two full turns. Push the button. Screw in the button until it is flush with the crank. Install the other button on the same way. Check that there is some play underneath the button when you push it (this play allows the gear to engage if you push it a little bit more).

Use a 2.0mm Allen wrench to firmly tighten the gear shift buttons. Use the little wrench that comes with every hub to hold the button against rotation. Check to make sure you cannot loosen the buttons by hand. If you have a torque screw driver at hand, use a torque of 2.0 Nm and you have a live long warranty against lost of gear shift buttons! Also available as accessory.

**Important:** When you push one button, its surface should be flush with the face of the crank, while on the other side, the **back** face of the button should be flush with the face of the other crank. When you are learning to shift, it is very tempting to make the buttons protrude further than this. Don't do it! It is actually easier to shift if they stick out the correct amount, and they are less prone to damage or falling off.

#### **7. Shifting problems after tightening spokes**

If shifting doesn't work as easily as before fitting the spokes, reduce tension on the spokes. Too high tension may result in a deformation of the hub body and can prevent the clutch pins from moving from one into the other position!



Picture 5: Mount crankarm and adjust axle bolt



Picture 6: Gear shift button is flush with the crank



Picture 7: Hold the gear shift button with the black wrench and tighten it well with an 2mm Allen wrench

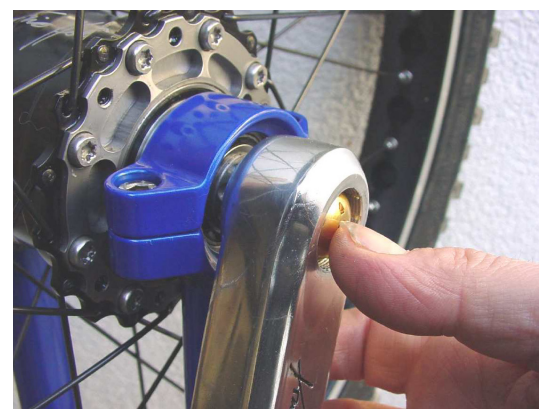

Picture 8: There must still be some play underneath the button if it is pushed!!

## Safety

### **1. Be Safe!**

Using a geared hub increases the risk of severe injury or death compared to a regular unicycle, due to factors including but not limited to high speeds, falls, longer stopping distances, equipment failure, and incorrect hub installation.

Always wear appropriate protective gear. Practice shifting at low speeds or dismount to shift if you are not comfortable shifting while riding.

This hub has been tested on both roads and rough terrain with drops up to 1.5 m. However, due to variables such as rider weight, skill, riding style, and terrain conditions, it is not possible to warranty this hub as fit for a particular level of terrain difficulty or drop height. While intended for mountain unicycling, it is not appropriate for aggressive freeriding (big drops) or trials.

Do not attempt to dismantle the hub. Doing so will void your warranty.

**Use common sense and ride within your limits!**

### **2. Checking crankarms from time to time**

Some problems had been reported with crankarms coming loose. Please make sure, that you have installed and tightened the crankarms and axle bolts as described before by using a torque wrench and a torque of 40 - 50 Nm (35 lbft).

Please use some medium strength Loctite to prevent the axle bolt from coming loose.

How to check the proper seat of the crankarms:

Hold the left and right crankarm and try to move them towards each other. If there is play between the crankarms (not between crankarm and wheel!), please unscrew the gear shift button and re-tighten the axle bolt immediately.

A loose crankarm can fall off and destroy the shifting mechanism!



Picture 9: High jumps: how high?

## Maintenance

### 1. How to change a crankarm?

a) Hold the gear shift button by means of the black wrench, loosen the M4-screw inside the button and unscrew the button.

b) Loosen the axle bolt with a 6mm Allen wrench.

c) **Very important:** For pulling off the crankarm, use an ISIS-puller with a pressure **plate with a diameter of at least 14mm** to avoid damaging the thin shifting shaft!! **Never** use the tube, that is used on square end axles!!!!!! It would penetrate and even destroy the axle thread!!

### 2. Cleaning

Don't clean the hub too often! If you do need to clean the hub, use some water, a sponge and cloth. Do **not** use high pressure water sprayers. Although the KH hub comes with sealed bearings of high quality, water will penetrate even sealed bearings after some time.

### 3. Regularly check the proper function of the hub

Regularly check that bearing housings are tight, the bearing housings are not damaged, and that the shifting mechanism is working properly.

Check the shifting mechanism as follows:

Hold the wheel against rotation and push the left button. There must always be some play underneath the button, to allow proper shifting. Rotate crankarm until gear audibly engaged. Push right button. Rotate crankarm again. After 24 shifting procedures, you have completed a full turn of the crankarms.

The gear must engage into all 24 positions without any friction.

**Never ride if there is any doubt of proper gear engagement!**

schlumpf innovations gmbh  
Dorfstr. 10  
CH - 7324 Vilters/Switzerland  
Tel: +41 (0)81 723 80 09  
Fax: +41 (0)81 723 83 64  
email: info@schlumpf.ch  
**www.schlumpf.ch**  
Geschäftsführer/CEO:  
Florian Schlumpf Masch.Ing.HTL



Picture 10: Loosen gear shift button

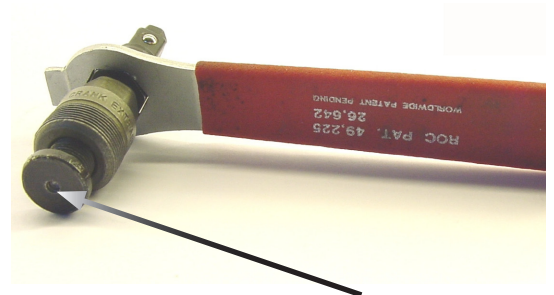

Picture 11: Crankarm puller. **Diameter of pressure plate must be at least 14mm.**



Picture 12: Check crankarm for sufficient space for gear shift button



Picture 13: Check shifting mechanism regularly!